

ideas make future

**BMW R50/5 - R100
(09/69-09/80)**

**ENGINE CONTROL UNIT
PLUG and PLAY – KIT
ENGLISH**

Ignition Kit Mounting Instruction Manual BMW R50 to R100 made between 09/1969 to 09/1980

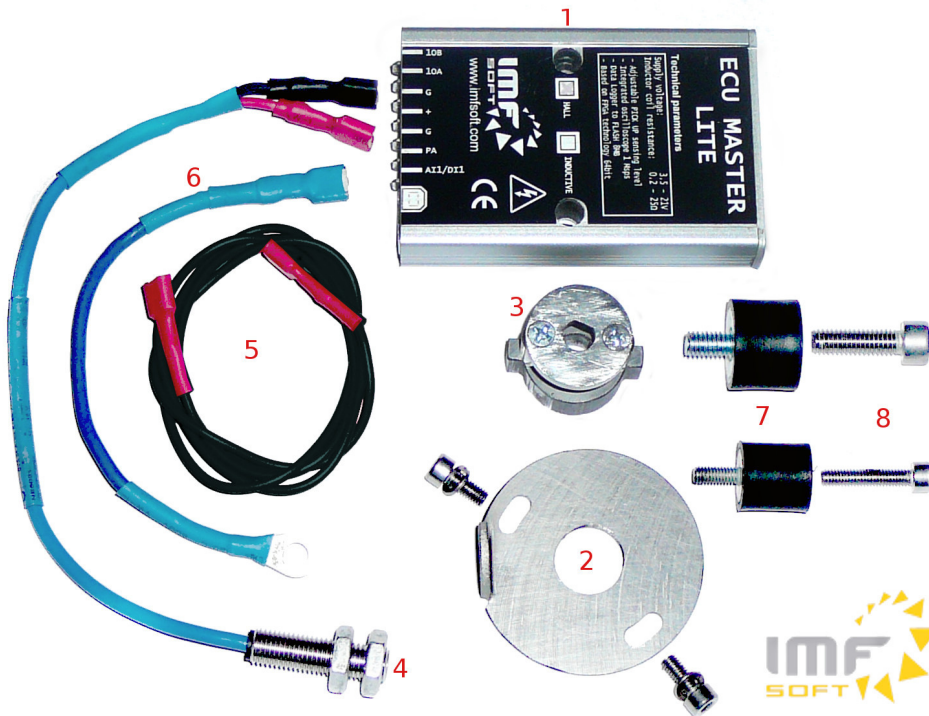

- 1x ECU MASTER LITE 80x55x16 mm
- 1x Induction sensor Pick-up M8x30
- 1x Triggerwheel 30 mm + Screw
- 1x Ignition base 50 mm + Screw
- 1x Silentblock M4 + Screw
- 1x Silenblock M6 + Screw
- 1x blue wire
- 1x red/black wire
- 1x CD with PC application

INSTRUCTIONS

1. Turn the ignition off or disconnect battery
2. Remove capacitor, hammer board, hammer cam and its cabling see picture.2
3. Mount new silent block M6 and M4 (part 7) to previous capacitor position
4. To the silent block fit new MASTER LITE using the screw M6x20 and M4x20 (part 8)
5. Mount sensor holder (part 2) using screws M4x10 and washer nuts
6. Mount trigger wheel (part 3), tighten the screws and tighten the original nut with washer
7. Mount pick up sensor (part 4) to sensor holder (part 2) **Tightening torque 2,5Nm**
8. Tune space between Pick up sensor (part 4) and trigger tooth (part 3) around 0,5mm
9. Connect pick up sensor (part 4) to unit MASTER LITE – pin **PA** and **G**, picture 4 and 5
10. Connect red wire (part 5) to unit MASTER LITE : pin „+“ and Ignition coil „+“ pole
11. Connect blue wire (part 6) to unit MASTER LITE : pin **G** and Ground on Alternator
12. Connect the original black wire from ignition coil to unit MASTER LITE : pin **10B** or **10A**
13. Turn the ignition ON or reconnect battery, turn the fuel ON
14. Software loaded in the unit is set to default, you can adjust the ignition maps if you wish.
Now you can enjoy new power of IMFsoft electronic ignition.

Picture 2 – old hammer ignition

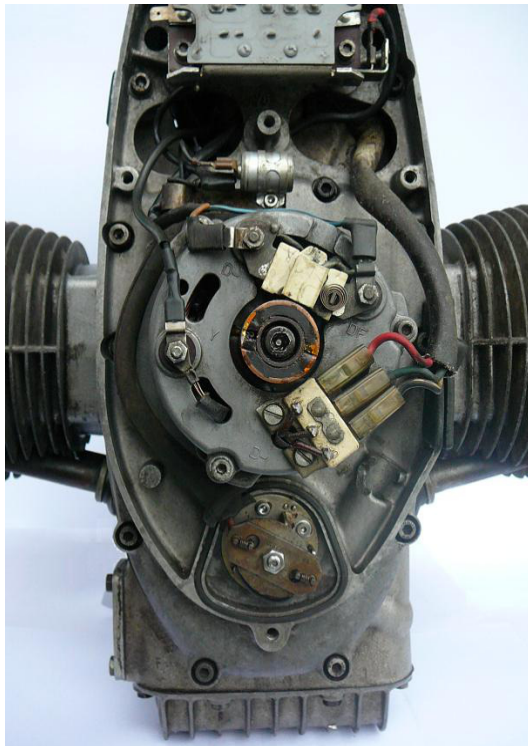

Picture 3 – new installation

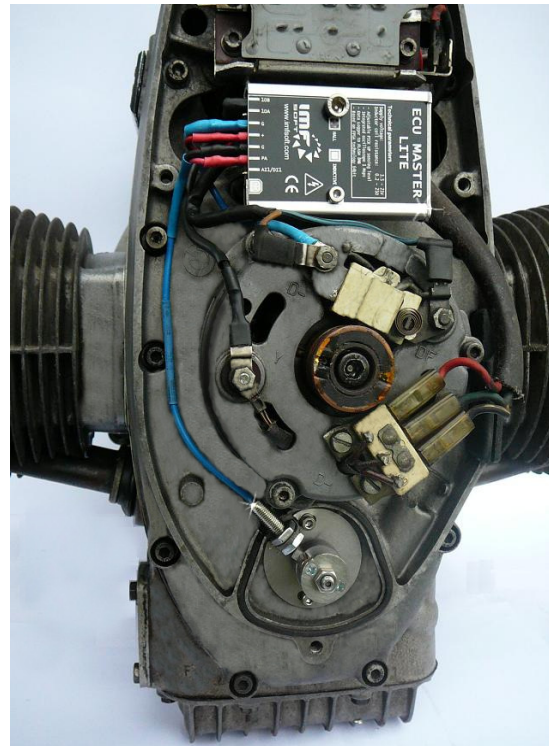

Picture 4 – ECU MASTER connection scheme

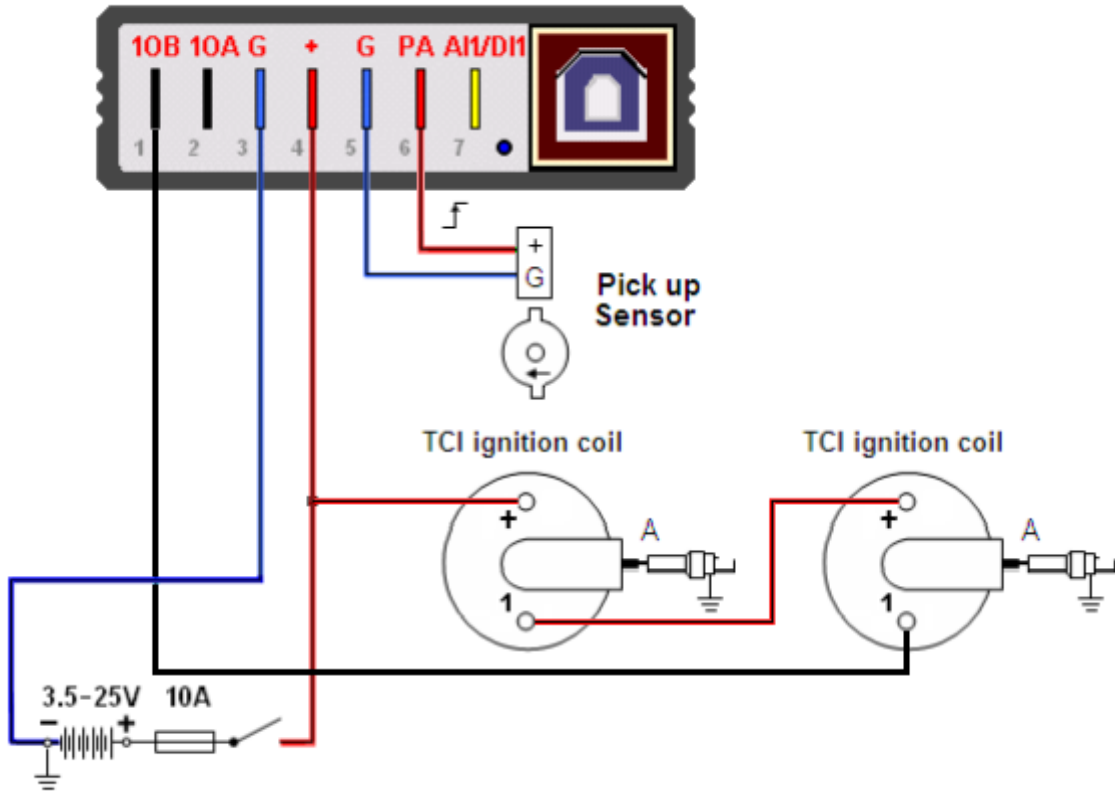

Picture 5 – ECU MASTER cable connection

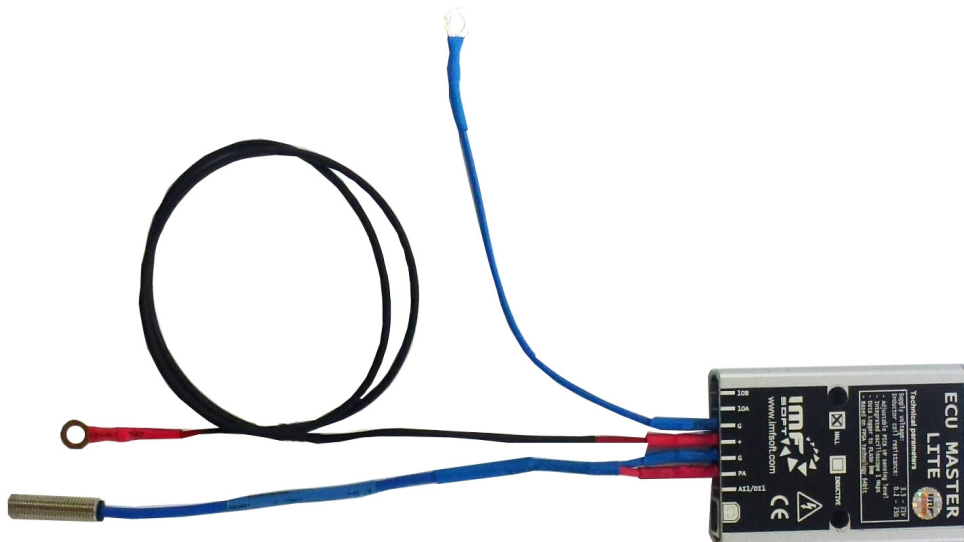

Picture 6 – ECU MASTER oscilloscope screen

